

 **ICE-CREAM
EQUIPMENT**



EXTRUSION LINES

ARCTIC M

STICK • SANDWICH • BAR/BONBON
SPECIALS • BALL CONE • WAFER CUP



Visit our sites



for more informations.

www.vojta.cz

A-ML4

automatic extrusion machine

A **Stick**
3.500 – 4.000 pcs/h

B **Ball Cone**
2.500 – 3.000 pcs/h

C **Sandwich**
3.500 – 4.000 pcs/h

D **Candy Bar**
3.500 – 4.000 pcs/h



A-ML6

automatic extrusion machine

A **Stick**
5.500 – 6.000 pcs/h

B **Ball Cone**
4.000 – 4.500 pcs/h

C **Sandwich**
5.000 – 6.000 pcs/h

D **Candy Bar**
5.000 – 6.000 pcs/h



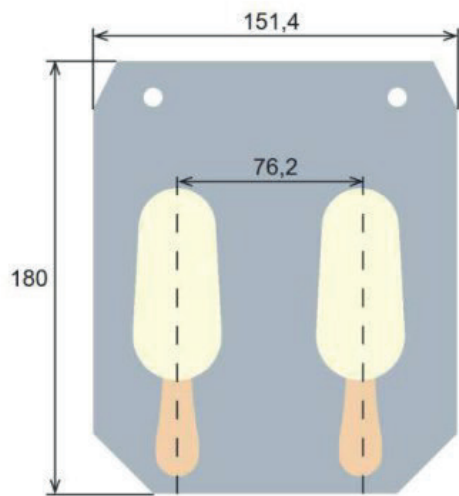

M-0002-60



M-0004-80

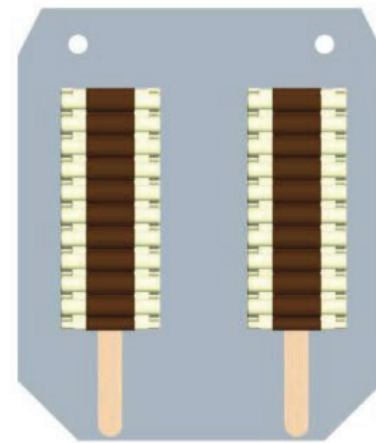

SP-0002-120

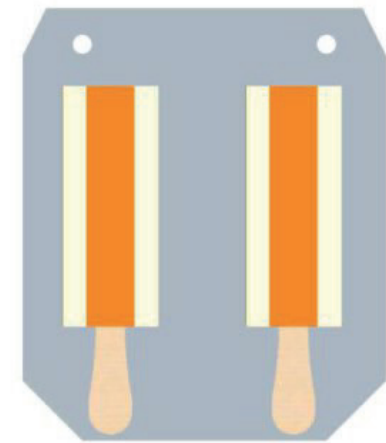

SP-0004-120

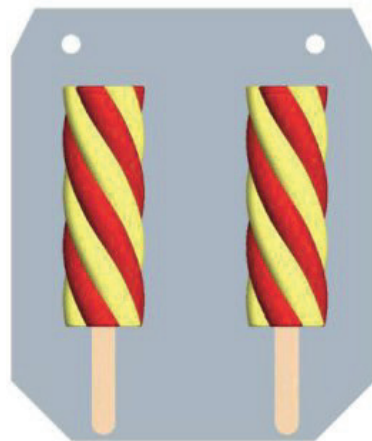

SP-0017-80

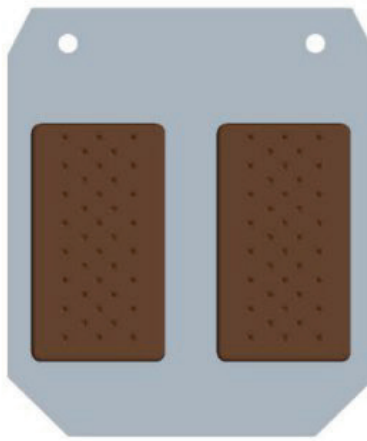

SH-0012-90



B-0001-60



C-0013-90



Standard STICK

- Dark chocolate coating
- White chocolate coating
- Coating with inclusions
- 2 Ice-cream rotary effect
- Rotary effect ice-cream/ topink



Funny Face STICK

- Up to 3 colors ice-cream product
- Almost any design possible
- Combination of water ice and ice cream possible



Max. product size:

- L x W x H = **105 x 60 x 30 mm** (2 products / tray)



Filling:

- Pencil filler
- Rotary effect ice-cream/ topink
- Rotary effect ice-cream/ ice-cream
- Up to 2 colors ice-cream product
- Inner/outer topink decoration

Dipping:

- Dark/White chocolate coating
- Coating with inclusions (nuts, almonds)
- Dry coating (nuts, almonds after choco dipping)



Max. product size:

- L x Ø D = **155 x 53 mm** (2 products / tray)



Cutting:

- Rotary effect ice-cream/ topink
- Rotary effect ice-cream/ ice-cream
- Up to 3 colors ice-cream product



Dipping (Half Sandwich only):

- Dark/White chocolate coating
- Coating with inclusions (nuts, almonds)

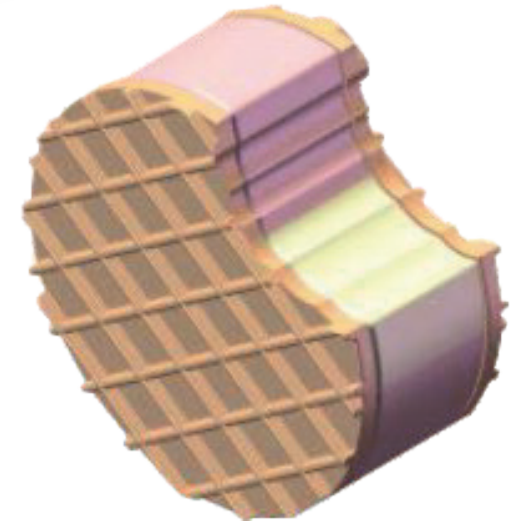

Max. product size:

- L x W x H = **120 x 55 x 30 mm** (2 products / tray)



Extruding:

- Pencil filler
- Caramel/toping top decoration
- Rotary effect ice-cream/ ice-cream
Up to 2 colors ice-cream product
Dry stuff decoration (nuts, almonds)

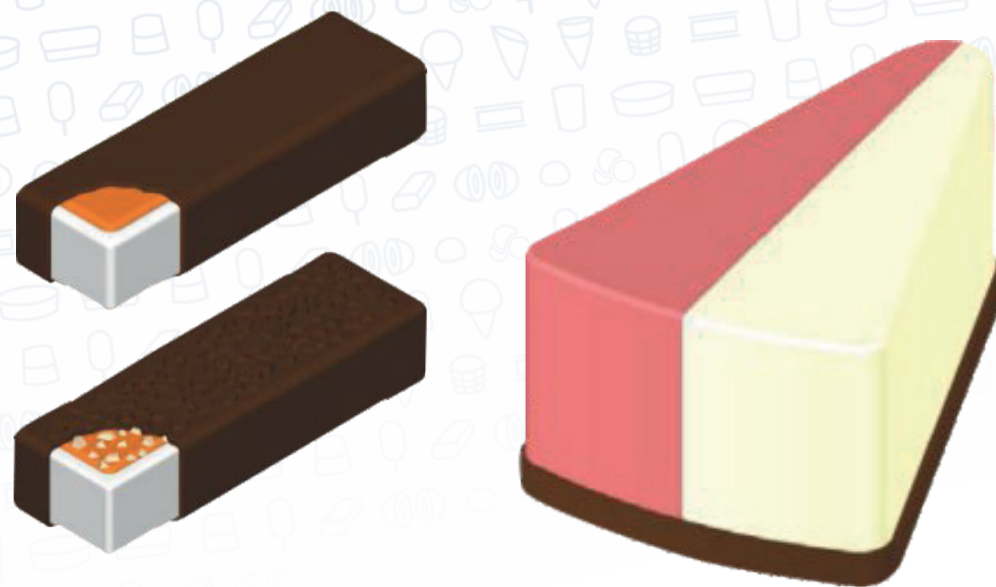

Enrobing:

- Dark/White chocolate enrobing
- Enrobing with inclusions (nuts, almonds)
- Second decoration (choco stripes)

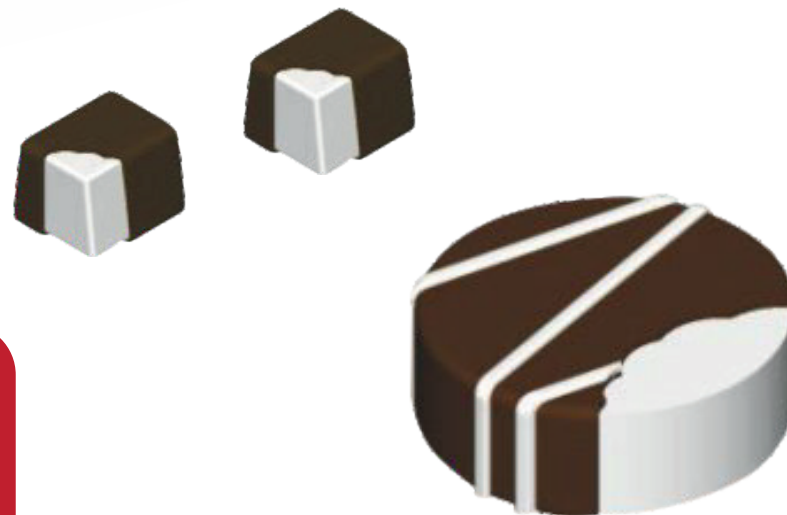

Max. product size:

- L x W x H = **135 x 50 x 30 mm** (2 products / tray)





Get more info
about **ARCTIC M**

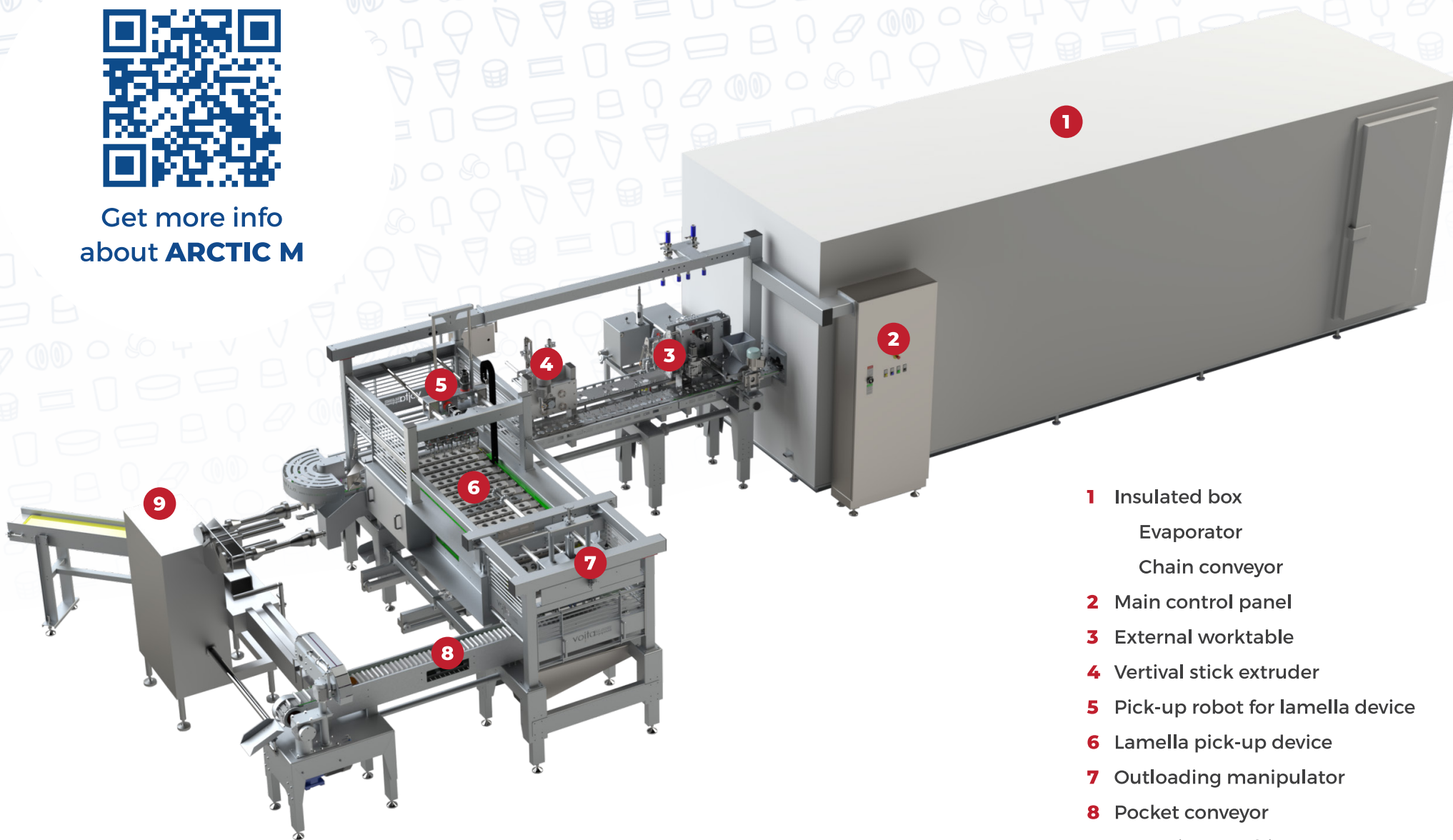

- 1** Insulated box
Evaporator
Chain conveyor
- 2** Main control panel
- 3** External worktable
- 4** Vertical stick extruder
- 5** Pick-up robot for lamella device
- 6** Lamella pick-up device
- 7** Outloading manipulator
- 8** Pocket conveyor
- 9** Wrapping machine





Get more info
about **ARCTIC M**

- 1 Filling station module
- 2 Sandwich + Extruder station module
- 3 Basic module

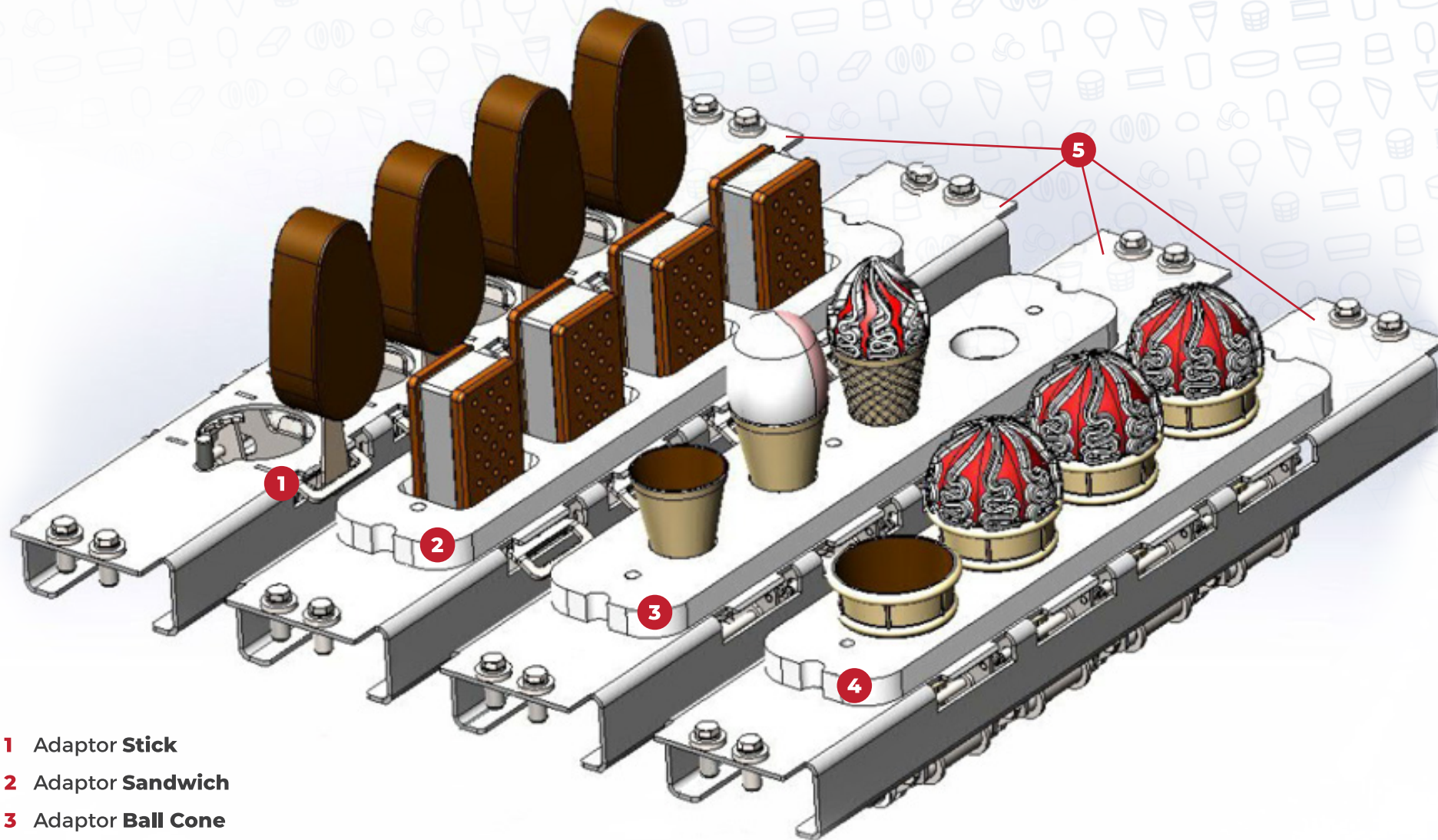

- 1** Adaptor **Stick**
- 2** Adaptor **Sandwich**
- 3** Adaptor **Ball Cone**
- 4** Adaptor **Wafer Cup**
- 5** Lamella Universal



Technical Specification:

Main Dimension
Length x Width x Height
1950 x 690 x 1700 mm

Freezing Capacity
35 kW / A-ML4
54 kW / A-ML6

Voltage
400 V / 50 Hz

Description:

Screw type BITZER compressors are used as standard. Whole cooling unit assembled and tested before transport.

- **Composition of 1 screw compressor:**

HSN-6451-40 for A-ML4

HSN-7461-70 for A-ML6

- **Compressors of world leading company**
- **Highly effective**
- **Low maintenance**

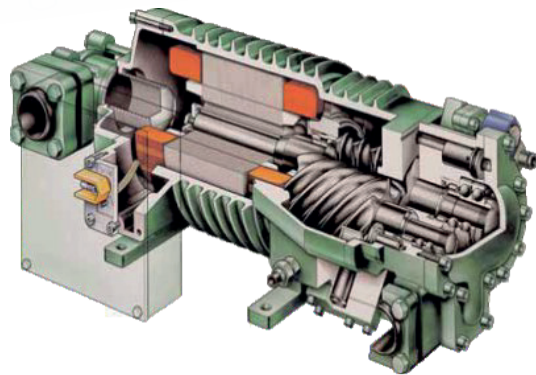

Technical Specification:

Main Dimension
Length x Width x Height
2150 x 1200 x 1950 mm

Product Dimensions
Length x Width x Height
200 x 90 x 70 mm

Consumptions
400 V / 50 Hz
4 kW

Description:

- Continuous flow-wrapping machine of ice cream products
- Fully "electronic wrapper", controlled by Siemens touch screen PLC, driven by servomotors
- System is designed to meet the highest standards of sanitation required by food industry
- Wrapping machine is synchronised via PLC unit and encoder with main movement of extrusion line
- Product placed directly onto wrapping foil – no contact with wrapper parts
- No damage of product during wrapping cycle
- Automatic reel splicer (optional)



Capacities: 5 500 – 6 500 pcs / hour



Technical Specification:

Main Dimension
Length x Width x Height
2150 x 1100 x 1950 mm

Product Dimensions
Length x Width x Height
200 x 90 x 70 mm

Consumptions
400 V / 50 Hz
3,8 kW

Description:

- Continuous flow-wrapping machine of ice cream products
- Fully "electronic wrapper", controlled by Siemens touch screen PLC, driven by servomotors
- System is designed to meet the highest standards of sanitation required by food industry
- Wrapping machine is synchronised via PLC unit and encoder with main movement of extrusion line



Capacities: 5 000 – 7 000 pcs / hour



NITROGEN PRODUCTION

Solero



„Double chocolate“ stick





SANDWICH ROUND

- Filled by ice cream with inclusions
- Outside embed with dry stuff (chocolate pieces, candies, etc.)

