

Technical Specifications

		LF-04	LF-06	LF-08
Hourly production max.	pcs/h	4 000 - 6 000	6 000 - 8 000	8 000 - 10 000

Product specification

Product pitch min.	mm	100	100	100
Product diameter max.	mm	90	90	90
Product height max.	mm	150	150	150

Media connections

Power input (400V/50Hz)	kW	1,1	1,1	1,1
Compressed air	bar	6	6	6

Other equipment on request.

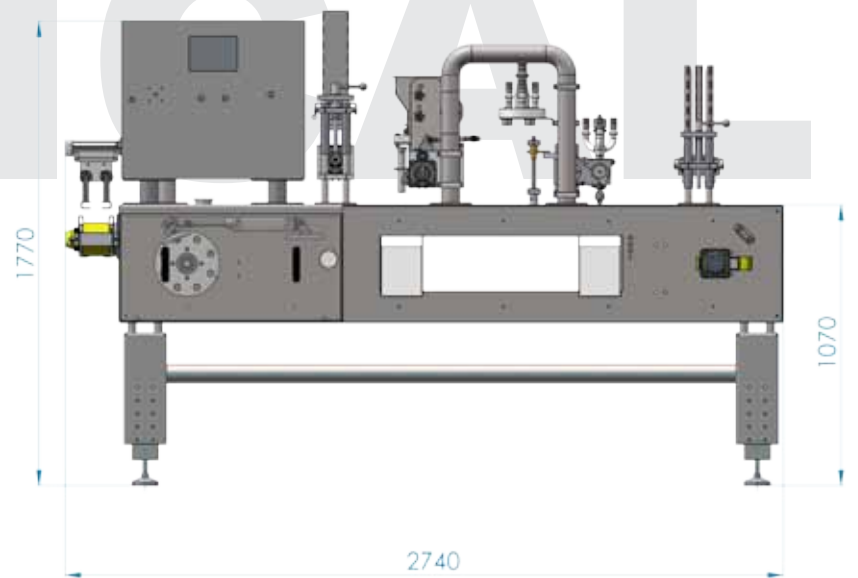

Machine layout

LF-04

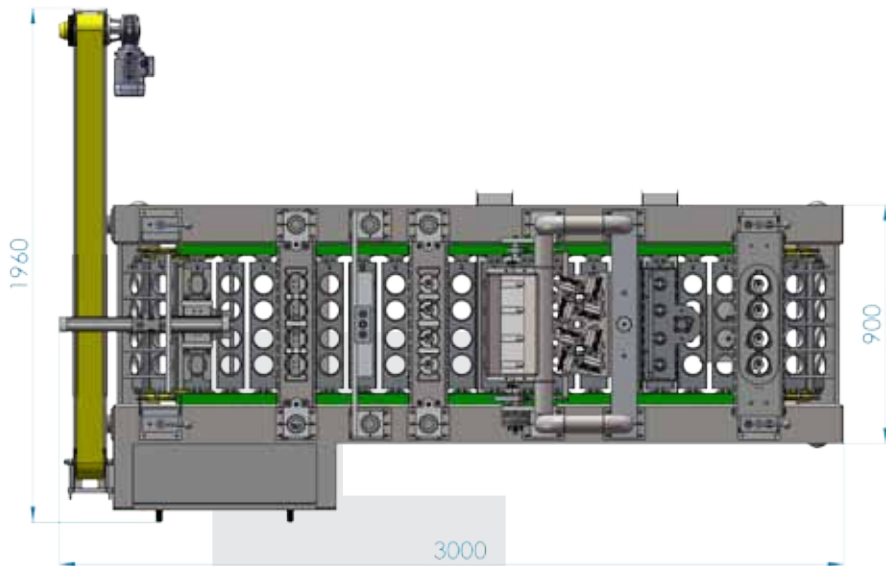

LF-06

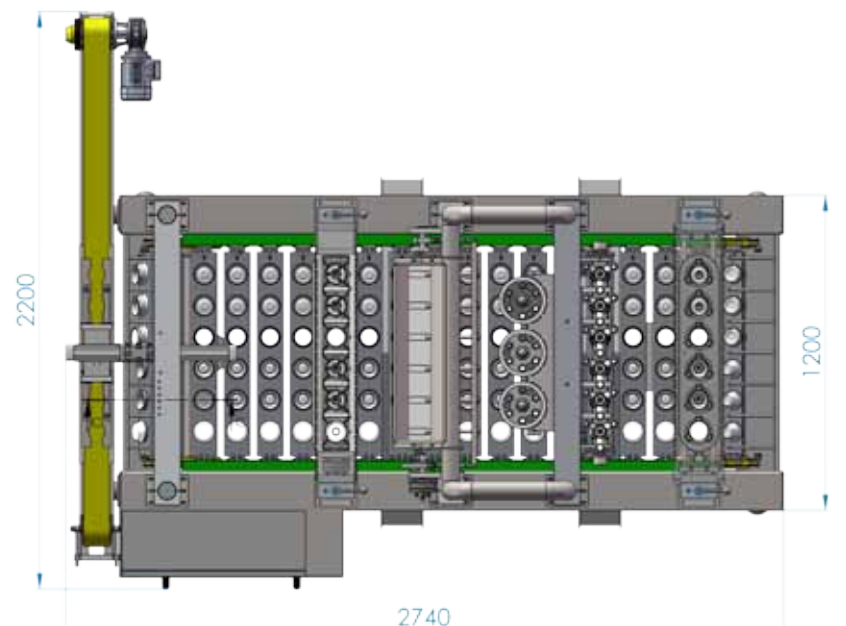

VOJTA s.r.o. product technology is under continuous development. Therefore we reserve the right to amend the information given in this brochure without prior notice.

VOJTA s.r.o.

Bratří Čapků 1844/17, 101 00 Praha 10, Czech Republic

Tel: +420 222 268 590, Fax: +420 222 268 599, Email: vojta@vojta.cz Web: www.vojta-equipment.com

vojta ice cream
equipment

LF-04/06/08

Capacity 4 000 - 10 000 pcs/h

Filling machine 4,6,8 wide

Quick product change over

Very compact design

Easy addition of extra stations

Possible automatic loading to HT

**Create Your Ideas,
We Will Find Solutions!**



Linear filling machine LF

Linear fillers LF are auto/semiautomatic filling machines for production of cups and cones.

Capacities from 4 000 pcs/hour (LF-04) to 10 000 pcs/hour (LF-08) are available.

Linear fillers LF can be linked to any type of hardening tunnel (HT) to complete the entire production process. This option is basically available for all type of **ARCTIC** extrusion tunnels, other hardening tunnels on request.

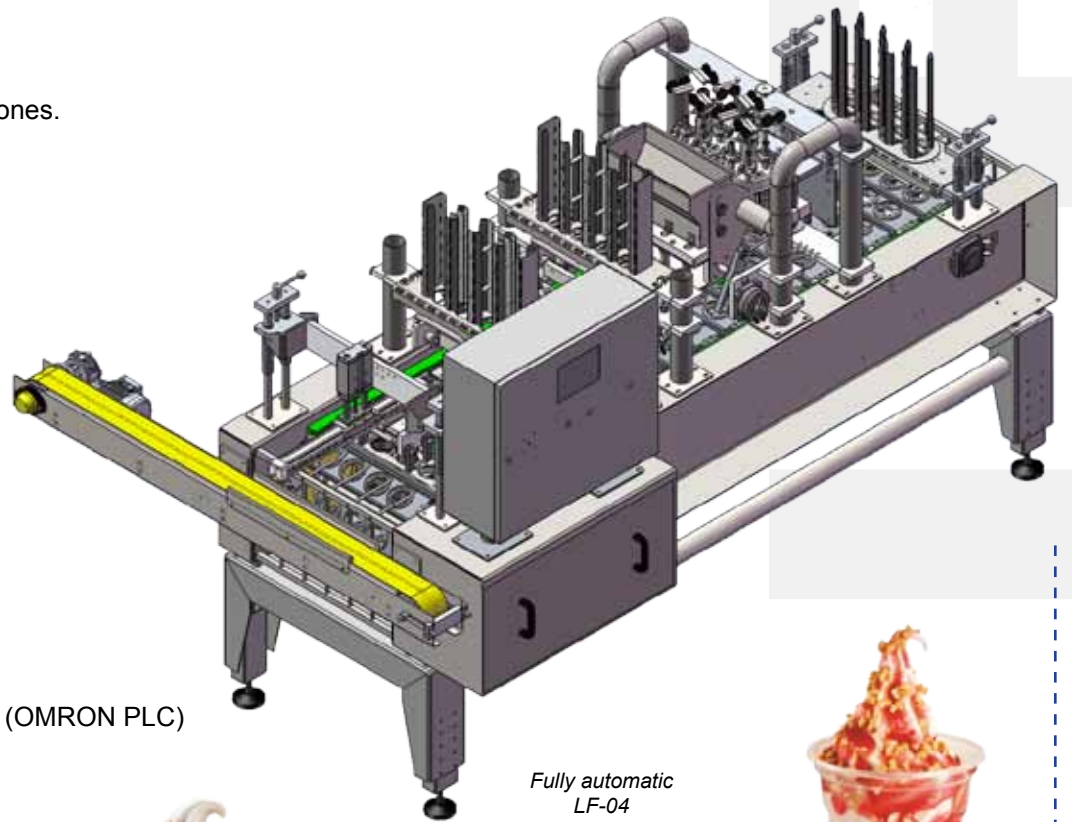

Fully automatic LF-04

Features:

- ▶ Strong stainless steel frame with adjustable legs
- ▶ Operator panel 5" LCD touch screen. Any possible languages on request
- ▶ Set of lamellas with 4/6/8 holes for plastic holders (one set of lamelleas included)
- ▶ Step-by-step pneumatic/servo lamella driver
- ▶ Electronic control panel in IP 65 protection rate with electric elements and control (OMRON PLC)



Filling station:

- ▶ Up to 3 colors
- ▶ Rotary filler (ice-cream/ice-cream, ice-cream/topink)
- ▶ Pneumatic or servodriver vertical movement
- ▶ Inner/outer topink and pencil filler possible
- ▶ 2nd filling station on request



Feeding station:

- ▶ Automatic empty packing feeding
- ▶ Exchangeable magazines
- ▶ Easy adjustable



Dry ingredients dosing station:

- ▶ Coating by nuts, almonds, cocoa powder etc.
- ▶ Adujstable volume of dosed indgredients
- ▶ Easy to operate



Lidding station:

- ▶ Automatic lid dispenser
- ▶ Plastic or paper lids possible
- ▶ Hot sealing of lids on request



Robotic transfer:

- ▶ Discharging of finished product
- ▶ Pneumatic motors operated
- ▶ HT transfer on request
- ▶ Easy adjustablet

Typical products made:

▶ Wafer cups

▶ Small cups*



S-0002-150

S-0008-130

S-0023-130

SC-0004-100

SC-0005-100

SC-0010-100

Any combination of ice cream shape with **chocolate, topink, pencil** or **dry ingredients** are possible. Other products on request.
*Max. diameter of cup 90mm

